

Tablet Cart

Secure, accessible tablet positioning at the point of care



Features

We've designed this cart to enable trusts to utilise tablets for EPR, patient surveys, translation services, and virtual ward rounds. Its small and lightweight design makes this cart easy to wheel out on busy wards and other congested areas.

The tablet is protected within a secure enclosure that's easy to wipe clean and can be rotated and height-adjusted to suit any user. It is compatible with a range of iPads and other tablets.

- ✓ Secure tablet enclosure can be tilted, rotated, and adjusted.
- ✓ Can be configured to allow for accessories.
- ✓ Strong and durable design that's built to last.

Benefits

- Small footprint and lightweight design makes the cart easy to position in tight spaces.
- Height adjustment for the tablet enclosure.
- Rear two wheels are lockable to ensure the cart remains stationary when in use.
- Designed for infection control and ease of cleaning.
- An ergonomically-designed base allows the user to find their perfect standing or seated position.
- Comprehensive 5-year cart warranty.

Areas of use

The versatility of this cart means it can be equipped for use in a range of different applications, such as:

- Virtual visits
- Electronic patient records
- Virtual ward rounds
- Patient surveys
- Translation and interpreting services

Compatible with

This cart can support any tablet that can be VESA-mounted to the profile. Example tablet models that can be fitted to these carts include:

- Apple iPad Mini – 7.9" screens
- Apple iPad Air – 9.7" screens
- Apple iPad – 9.7" and 10.2" screens
- Apple iPad Pro – 9.7", 10.5", 11" and 12.9" screens
- Microsoft Surface Pro – 10.6", 12", 12.3", and 13" screens
- Microsoft Surface Go – 10", 10.5", 10.6", and 10.8" screens
- Samsung Galaxy tablets (A & S series) – 8.7", 9.7", 10.1", 10.5", 11", 12.4", and 14.6" screens

Tablet Cart

Secure, accessible tablet positioning at the point of care

Drawings

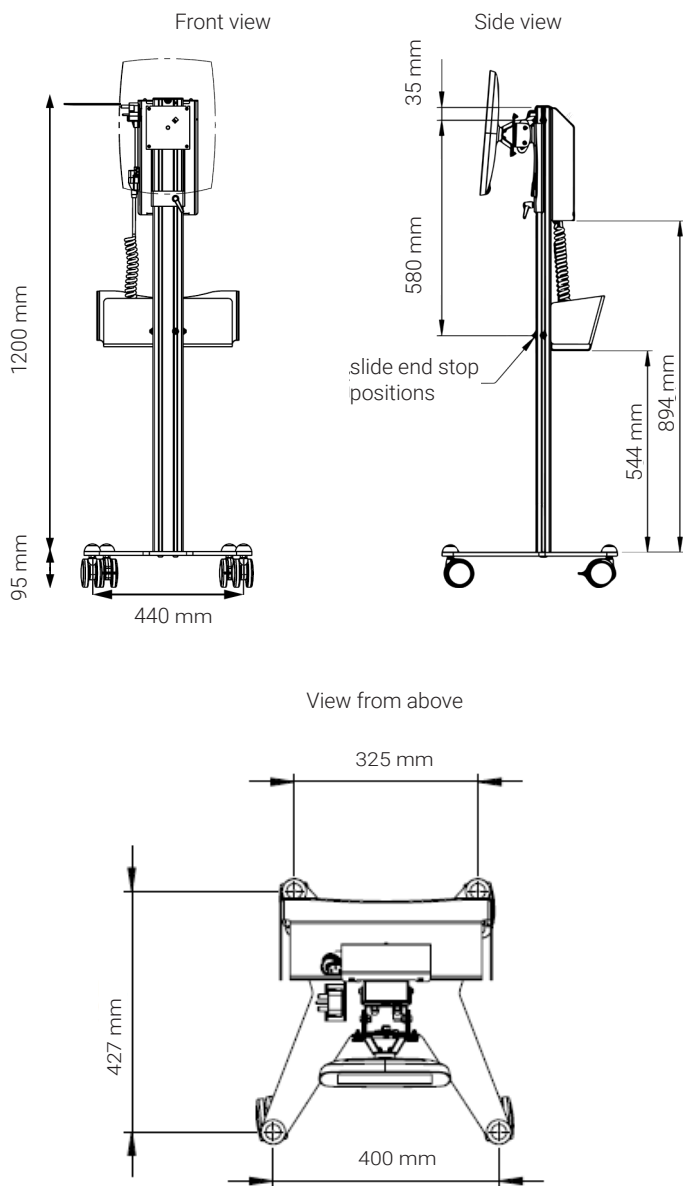

Main specifications

Height (to top of mast)	1295 mm
Tablet fixture (central point)	930 mm (lowest) to 1220 mm (highest)
Weight (base cart only)	14.1 kg
Cart base dimensions	400 mm (width) x 427 mm (depth)

Approved cleaning solutions

- AF anti-bac sanitising surface wipes
- AF anti-bac+ sanitising screen wipes
- Wonder Wipes multi-use cleaning wipes
- Clinell universal wipes tub
- Clinell disinfectant spray
- Clinell alcohol wipes
- Clinell alcoholic 2% chlorhexidine device wipes
- Novus plastic cleaner



Direct purchase



Made in the UK



Project management



Device configuration



Phased delivery



Instant support

Common accessories



File storage



External speaker

Version 2.1

