

VersaLite MedDrawer

Versatile, simple, and secure storage workstation



LiFePO4 battery

Electric height adjustment

SmartPower option available

This cart is designed to be used with different computers and devices. Our medical-grade Infinity all-in-one PC is shown on the cart above and features:

- A large, intuitive touchscreen.
- Dual hot-swappable batteries for 24/7 constant power.
- Powerful CPU, ultra-fast SSD and up to 64GB system memory.
- Unique battery management software with remote monitoring.
- Front panel is IP65 rated for protection from water and dust.
- 3-year warranty.

For more info on our Infinity all-in-one PCs or to enquire about a cart bundle package, please get in touch with our sales team, who will be happy to help. Our contact details are below.

Compatible with



Infinity all-in-one PC



Micro PC*



Laptop

*Requires SmartPower

Features

Our smallest, lightest, height-adjustable ePMA cart is great for providing storage and is easy to move in congested areas.

- ✓ Simple hand-operated height adjustment.
- ✓ Lockable drawer is easy to access quickly when needed for more efficient dispensing.
- ✓ Modular design allows for the addition of a range of accessories and drawer configurations. Digi, keyed, and RFID lock options are available for secure storage.
- ✓ Work surface is durable and resistant to hospital cleaning agents.

Benefits

- Small footprint makes the cart easy to position in busy bays.
- Conveniently placed grab handles allow precise and easy movement.
- Large rear castors provide smooth and stable movement even across uneven surfaces, such as thresholds.
- Designed for infection control and ease of cleaning.
- An ergonomically designed base allows the user to find their perfect standing or seated position.
- Comprehensive 5-year cart warranty.

Areas of use

The VersaLite MedDrawer is ideal for providing access to electronic patient records or medication notes in areas such as:

- A&E / ED
- Theatres
- Wards

VersaLite MedDrawer

Versatile, simple, and secure storage workstation

Drawings

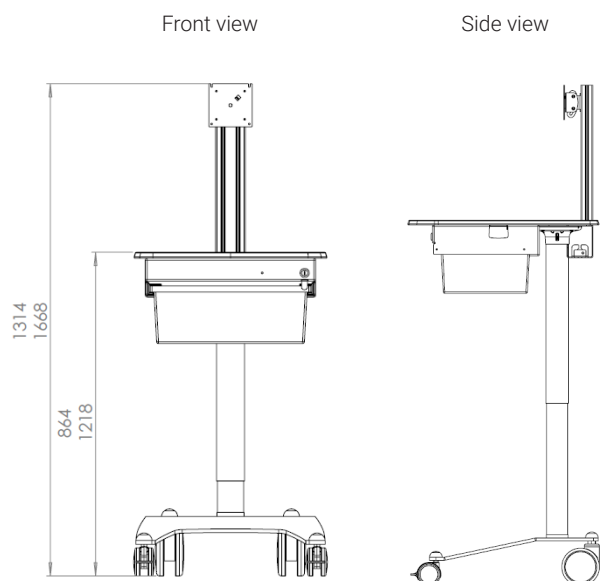

View from above

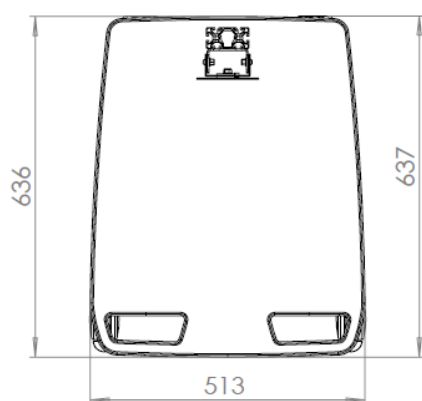

Main specifications

| | |
|------------------------------------|--|
| Work surface height (extended) | 1218 mm (unpowered) 1223 mm (powered) |
| Work surface height (compressed) | 864 mm (unpowered) 923 mm (powered) |
| Weight (base cart only) | 31 kg |
| Weight (base cart with SmartPower) | 46 kg |
| Work surface dimensions | 513 mm (width) x 636 mm (depth) |
| Unpowered cart base dimensions | 515 mm (width) x 627 mm (depth) |
| Powered cart base dimensions | 505 mm (width) x 642 mm (depth) |

Approved cleaning solutions

- Quaternary ammonium chloride compounds (such as AirX109)
- Bleach-Household strength (1:10 minimum dilution strength)
- Ethyl or Isopropyl alcohol-70%
- Hydrogen Peroxide
- Phenolic disinfectants (such as Lysol, WexCide)
- Ovation
- Fantastic
- Formula 409
- 1.6% Aqueous Ammonia
- "Green Soap" USP (United States Pharmacopoeia)
- Clinell Wipes
- Chlor Clean



Direct purchase



Made in the UK



Project management



Device configuration



Phased delivery



Instant support

Common accessories



Printer



Scanner



Medical keyboard & mouse

Version 2.2

